



# Highly Efficient, Light, and Compact Inverter-Driven Packaged Air-Conditioner

NOBUYUKI TAKEUCHI\*1  
 ATSUYUKI SUMIYA\*1  
 YOSHIZUMI FUJITA\*1

TAKANORI NAKAMURA\*1  
 TAKAMASA WATANABE\*1  
 MITSURU NAKAMURA\*2

Because of environmental problems, in recent years air-conditioners have been required to improve their fundamental performance such as high efficiency and low energy consumption. From the standpoint of installation, however, air-conditioners must be lighter and more compact. In order to respond to these contradictory needs, an inverter driven packaged air-conditioner has been developed by employing a high performance DC inverter compressor that reduces its seasonal power consumption by 30% and its weight and size by 35 - 60% compared with former model. This paper introduces the newly developed air-conditioner and reports on the methods used to achieve high efficiency, light, weight and compactness.

## 1. Introduction

With the concerns over global environmental problems increasing among users in recent years, legal controls are also being established such as the introduction of European RoHS Directive, control over hazardous substances, etc. Thus, air-conditioners are required to have higher efficiency and lower energy consumption, taking account of environmental problems. The installation companies, on the contrary, demand compactness and easy installation such as reduction in size and weight.

This paper reports on a newly developed outdoor unit with drastically reduced size and weight and with enhanced performance compared with existing constant speed units in order to meet with these needs.

## 2. Outline of the inverter driven outdoor unit

### 2.1 Compact, lightweight construction

Figure 1 shows the appearance of the newly developed inverter-driven outdoor unit compared with a former one.

For the 4 - 6 hp unit, by adopting a small high efficiency compressor, a DC fan motor and a high performance heat exchanger, a single fan can be used instead of the former two fan model. This results in a drastic weight reduction (50%) from 125 kg to 63 kg for a 6 hp unit, and a height reduced by 455 mm resulting in a compact unit with 35% less volume.

For the 8 - 10 hp unit, the former upward blow type has been replaced with a horizontal blow type for the first time in this industry, allowing more effective use of the heat exchanger, while employing a DC fan motor and a high performance scroll compressor ensures excellent performance.

For this unit too a drastic reduction of weight (38%) from 225 kg to 140 kg has been achieved with a volume reduction of 67% for the 10 hp unit. In particular, the installation area has been reduced by 63%, making installation possible in a smaller space.

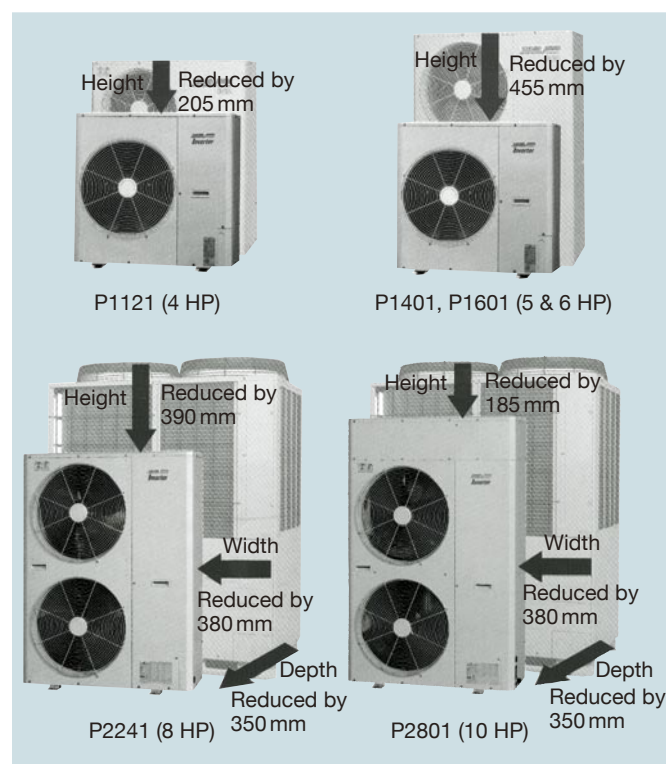

Fig. 1 Appearance of inverter-driven outdoor unit

The newly developed unit is shown from the front and the former unit from the rear for comparison, indicating the drastic size reduction.

By realizing a lighter, more compact unit compared with the former unit, the new unit is much more convenient to transport and carry in elevators.

### 2.2 Energy saving performance

The average cooling and heating COP (coefficient of performance = energy consumption efficiency) of the new unit is shown in Fig. 2. While former units are a combination of a constant speed compressor and an AC fan motor, the new unit adopts a DC inverter-driven compressor and a DC fan motor for higher efficiency and a high performance heat

\*1 Air-Conditioning & Refrigeration Systems Headquarters

\*2 Nagoya Research & Development Center, Technical Headquarters

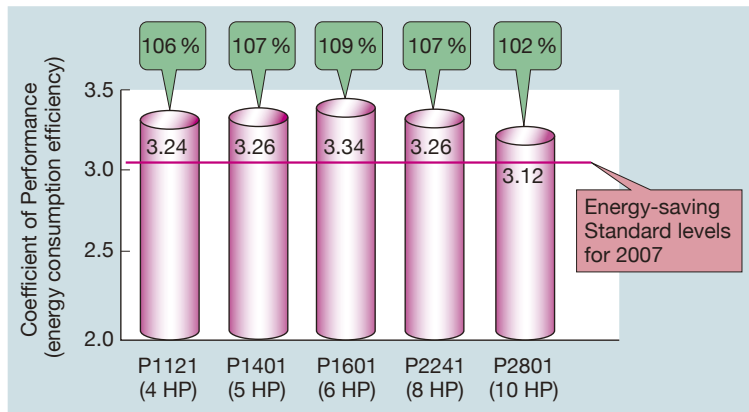

**Fig. 2 Average COP at heating and cooling**  
All units of all hp levels have cleared the Energy-saving Standard levels of 2007.

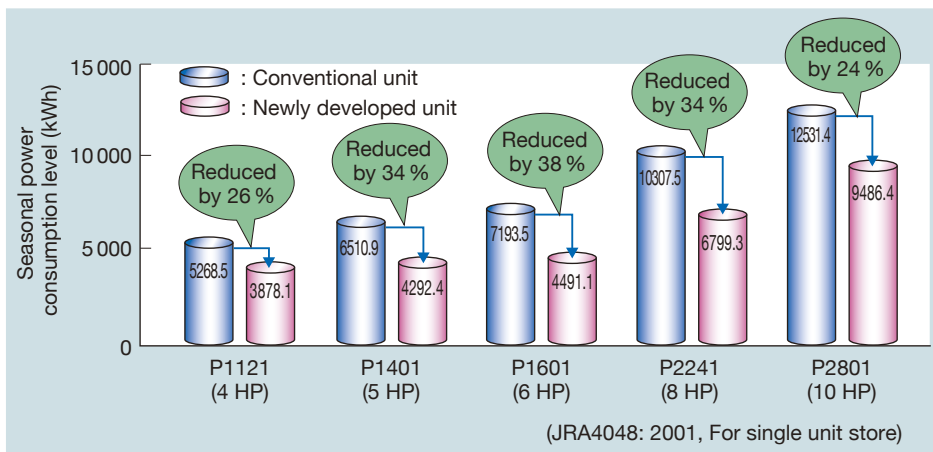

**Fig. 3 Comparison of seasonal power consumption levels**  
The power consumption levels are drastically reduced in all hp classes compared with former units.

exchanger to ensure a higher average cooling and heating COP. Therefore, except for some combined indoor units, almost all the units in the series clear the 2007 standard levels of the Japanese Energy Saving Law, and can be labeled as conforming to the European RoHS Directive.

Further, with optimized control due to the adoption of the inverter, the seasonal power consumption for the 6 hp unit has been drastically reduced by 38%, reducing power charges. (Fig. 3)

### 3. Development of component

#### 3.1 Development of small high performance compressor

Figure 4 shows the appearance of the newly developed compressor, compared with a former compressor, fitted to a 4 - 6 hp air-conditioner. An inverter-driven, rotary compressor is used instead of the former constant speed scroll compressor in order to reduce its size. Further, the high efficiency DC brushless motor is highly efficient over a wide range, reducing the annual power consumption.

In order to reduce the size of a compressor, it is necessary to widen its operating range to high rpm, which involves overcoming the problems below.

(1) Lowered oil level due to an increase in oil discharge.

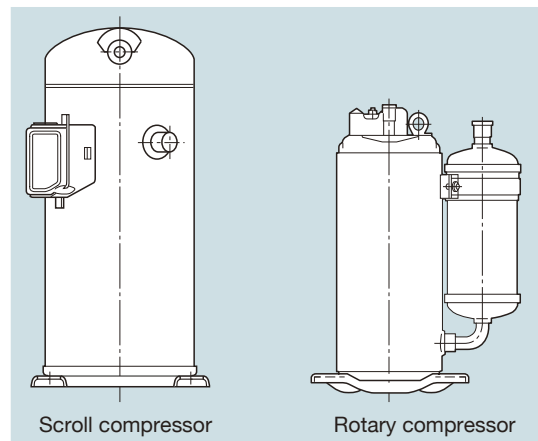

**Fig. 4 Newly developed inverter-driven, rotary compressor compared with conventional, constant speed, scroll compressor**  
Newly developed unit drastically reduced in size.

(2) Increase vibration due to shaft whirling.

(3) Generation of abnormal sounds due to vertical vibration of the motor.

The first problem is overcome by improving the oil feeding path by viewing behavior of the oil inside the compressor.

By optimizing the motor balance weight through dynamic analysis of shaft deflection, vibration is reduced. Finally, sounds were eliminated by optimizing the shaft thrust area through a vibrational analysis of the oil-film damping of the shaft thrust section.

Thanks to these improvements, a reduction of approximately 58% was realized compared with the constant speed compressor used in the same class outdoor unit, in addition to high reliability and large improvements in efficiency.

### 3.2 Vector-controlled inverter

Due to the employment of a vector-controlled, sinusoidal waveform, drive-type inverter in place of the 120 degree, power-on, drive-type inverter previously used, a compressor motor with high rotations could be used, ensuring both high efficiency during rated operation (reduced if inverter loss occurs due to decrease in motor current and reduced if motor core loss occurs due to decrease in motor voltage harmonics) and high speed operation due to the expansion of a weaker magnetic flux control range.

In addition, the motor start control has been improved by using power voltage correction and motor current control using vector control.

Thus, the reduction in motor current due to the high speed compressor and motor current control reduce the power transistor capacity and allows it to be used to its ultimate capacity. Moreover, the miniaturization of the power device through improved semiconductor technology contributes to the realization of small lightweight controller.

### 3.3 DC fan motor

In order to enhance the total efficiency of the unit, a brushless, DC fan motor with faster fan speed change is

used. The motor has a greatly reduced winding length by using intensive winding instead of distributed winding contributing to higher efficiency owing to reduced copper loss and to smaller size and weight. **Figure 5** shows the difference between distributed winding and intensive winding.

Further, eliminating the sequence of turning on the power source and then the control power has improved reliability.

### 3.4 High-efficiency heat exchanger

With a smaller unit and a smaller heat exchanger setting, the air flow is decreased, calling for a highly efficient heat exchanger. In the new unit, the number of fins has been increased by using straight fins for the heat exchanger, and by making a highly efficient groove on the inner surface of the tube, the heat exchange area for both the air and refrigerant sides have been increased, which improves the efficiency of the heat exchanger. Besides, the fin is surface treated to decrease the water retention of the heat exchanger and improve the frost resistance.

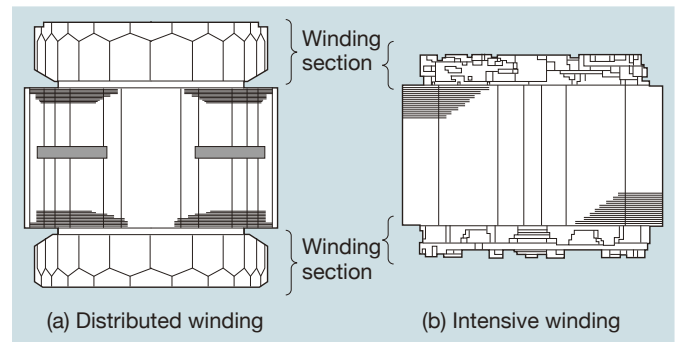

**Fig. 5 Difference in motor winding**  
Reduced winding section are shown.

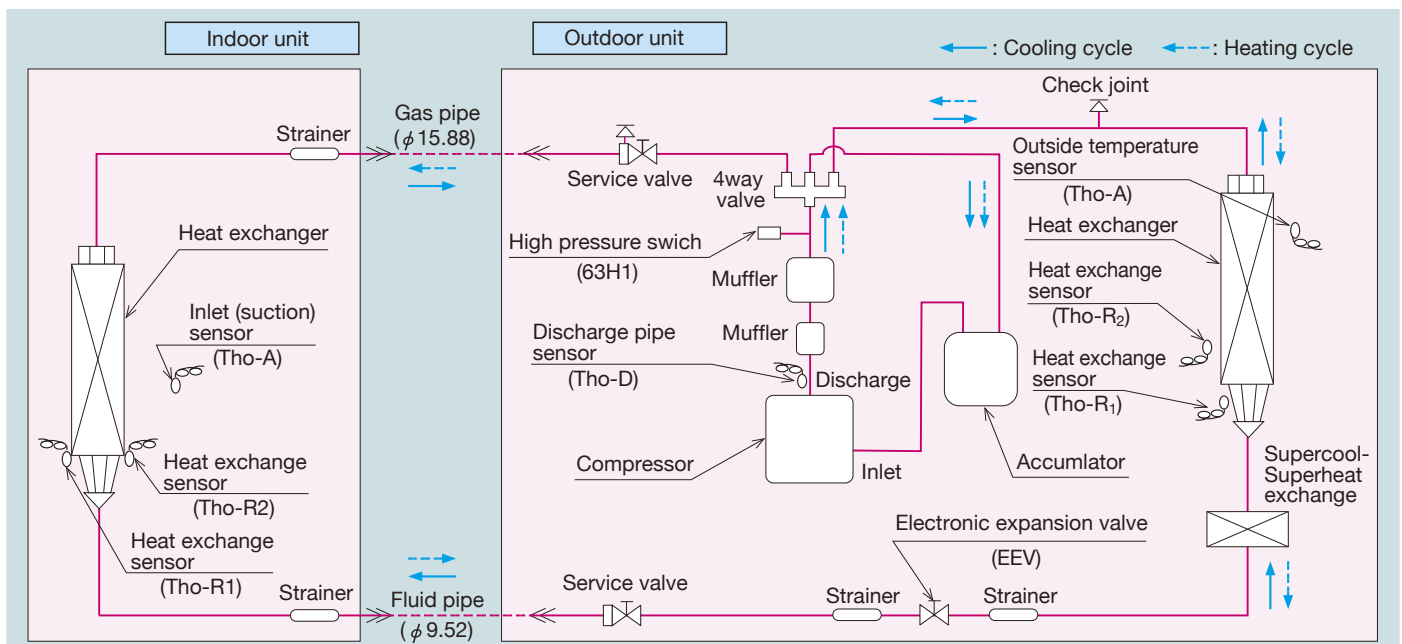

**Fig. 6 Accumulator circuit**  
Accumulator located at the inlet of the compressor allows direct flow of refrigerant.

### 3.5 Refrigerant circuit

Compared with the accumulator circuit (Fig. 6) in a former constant-speed unit, the newly developed circuit protects the compressor from being damaged by the accumulator during oil return. In former units, since the accumulator accumulates the surplus refrigerant in a 2 phase state, the inlet pipe of the compressor has a constant 2 phase flow of liquid and gas. Since a 2 phase flow causes the pressure loss to increase by 1.6 times of a single-phase flow, the air-conditioner efficiency eventually deteriorates.

In the new unit a receiver circuit equipped with two electric expansion valves (Fig. 7) is used. The circuit accumulates the surplus refrigerant in the receiver for optimum control of the degree of superheating and supercooling using the electric expansion valves. This keeps the inlet refrigerant of the compressor in a constant superheated gas state reducing the pressure loss. Accordingly, since the receiver circuit reduces the pressure

loss of the refrigerant, the heat exchanger can be more compact. Further, since the electric expansion valves prevent oil return to the compressor, the compressor is protected from damage by fluid compression, and bearing wear because of refrigerator oil dilution is eliminated resulting in enhanced compressor reliability.

### 4. Workability

The newly developed unit is compact compared with a former unit, but has the same maximum piping length of 50 m for a 4 - 6 hp unit, and 70 m for 8 and 10 hp units (Fig. 8). Further, similar to the former unit, there is no need for additional charging of refrigerant up to a piping length of 30 m.

The new unit features reuse of pipes without washing for up to 50 m of existing pipe provided that the compressor has no history of problems. This leads to the saving of installation work due to the reduction in pipe material, pipe removal and disposal costs.

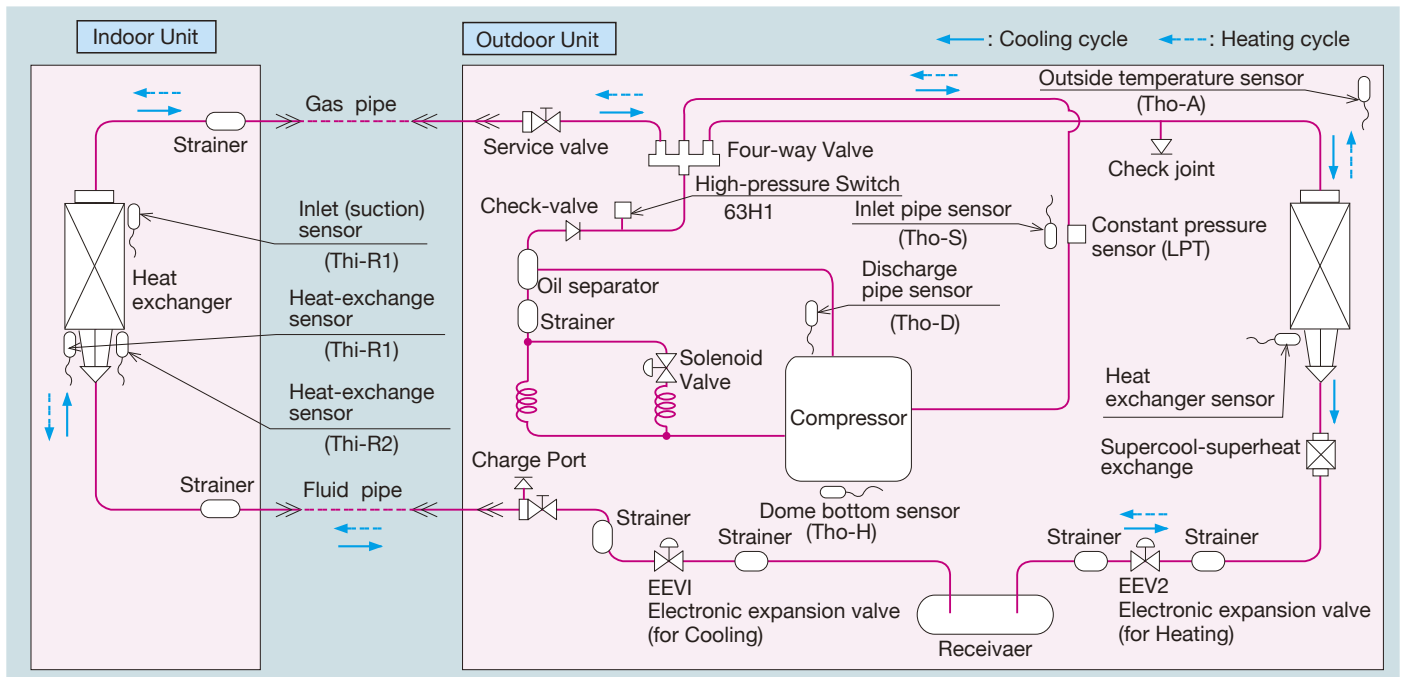

**Fig. 7 Receiver circuit**  
The receiver is located far from the compressor, where the surplus refrigerant is controlled.

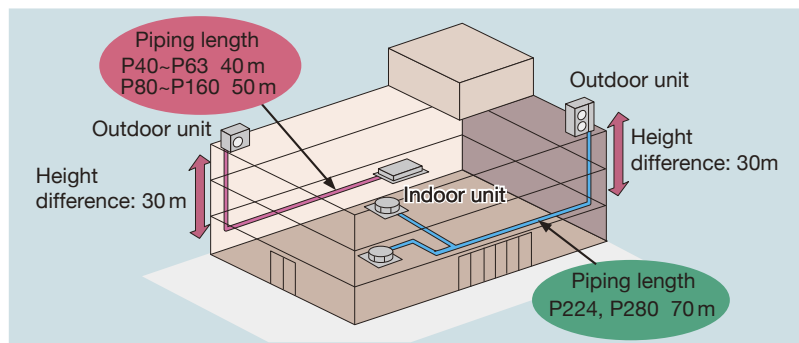

**Fig. 8 Installation piping length**  
Indicates the limits of total piping length and height difference of the installation pipes.

Further, the new unit is equipped with a pump-down function, ensuring convenient reinstallation. The pump-down function allows automatic accumulation of the refrigerant into the outdoor unit, eliminating the need for recovery or adding refrigerant during reinstallation, thus improving the workability.

## 5. The environment

To respond to environmental problems, the use of hazardous substances in the product is restricted, and the lead-free PC boards are used. Export products conforming to EU RoHS have already been launched on the market, while products for domestic use are scheduled to gradually meet

the standards of J-MOSS, the Japanese version of the RoHS Directive, before it is established.

## 6. Conclusion

A range of 4 - 10 hp inverter-driven, outdoor units with high efficiency and low energy consumption in addition to improved installability because of a drastic reduction in size and weight have been developed. Further, the newly developed unit conforms to the RoHS Directive and is environmentally friendly.

We are determined to further reduce seasonal power consumption and improve heating performance.



Nobuyuki Takeuchi



Takanori Nakamura



Atsuyuki Sumiya

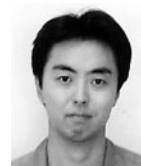

Takamasa Watanabe



Yoshizumi Hujita



Mitsuru Nakamura